

PRACTICAL METHOD FOR APPEARANCE MATCH BETWEEN SOFT COPY AND HARD COPY

Naoya Katoh

Corporate Research Laboratories, Sony Corporation,
Shinagawa, Tokyo 141, Japan

ABSTRACT

CRT monitors are often used as a soft proofing device for the hard copy image output. However, what the user sees on the monitor does not match its output, even if the monitor and the output device are calibrated with CIE/XYZ or CIE/L*a*b*. This is especially obvious when correlated color temperature (CCT) of CRT monitor's white point significantly differs from ambient light.

In a typical office environment, one uses a computer graphic monitor having a CCT of 9300K in a room of white fluorescent light of 4150K CCT. In such a case, human visual system is partially adapted to the CRT monitor's white point and partially to the ambient light.

The visual experiments were performed on the effect of the ambient lighting. Practical method for soft copy color reproduction that matches to the hard copy image in appearance is presented in this paper. This method is fundamentally based on a simple von Kries' adaptation model and takes into account of the human visual system's "partial adaptation" and "contrast matching".

1. INTRODUCTION

Device independent color reproduction has been recognized as the technology in the color imaging that will enable users to capture, display, and print color images which look the same across different devices. A number of system-based and software-based color management systems (CMS's) has already been on market to achieve this environment. These CMS's consist of

- 1) intermediate color space(s),
- 2) transformation method between color spaces, and
- 3) transformation tables from device-dependent color to device-independent color for each device.

Transformation tables for each device are often called "device profiles". With these CMS's, input image data is transformed into intermediate color space through the input device's profile, and then transferred to the output device through the output device's profile. Thus, users can obtain "device independent color" across different devices.

CIE 1976 L*a*b* has recently been recognized as a standard "device-independent" color space by divers field of color systems because it is perceptually equal color space and because the human visual system's adaptation to the surround is considered to some extent. The color space working group (WG2) of the color facsimile expert group in Japan has selected CIE 1976 L*a*b* as a mandatory color space in its communication signal¹ and some of the existing image editing software is already supporting CIE/L*a*b* format images.

However, present CMS's hold some inevitable technical problems. These problems include:

- 1) Calculation error through the image transformation.
- 2) Instability of the devices.
- 3) Measurement of the fluorescent materials .

- 4) Gamut difference between the devices.
- 5) Appearance difference according to the surroundings.

In this paper, appearance difference between the soft copy image and the hard copy image is discussed. With present CMS's, hard-copy-to-hard-copy matching could be achieved within the precision of the CMS's calculation and the device's stability if all the input colors are inside the output device's color gamut. However, the reproduced soft copy image on CRT monitor using CIE/L*a*b* or CIE/XYZ has an acceptable match only under limited viewing conditions. This is because the human visual system changes sensitivity according to the surround conditions. Thus, appearance models are necessary to solve this surround effect.

Several color appearance models have been proposed and some of the models^{2,3,4,5,6} have produced very accurate predictions of changes in color appearance. However, since they tried to predict color appearance for complete range of viewing conditions, these models need a significant number of parameters and are somewhat too complex to implement. Furthermore, they are not compatible with CIE 1976 L*a*b*, which is widely accepted by the industry, except for RLAB⁴ recently proposed by Fairchild and Berns. Most importantly, soft copy images under ambient lighting are not yet evaluated.

Therefore, the objective of the method presented in this paper is:

- 1) to have a better prediction of self-luminous color under ambient lighting, and
- 2) to be compatible with CIE 1976 L*a*b*.

This method is limited to a range of typical office viewing conditions, not a complete range of viewing conditions. Therefore, color appearance changes with luminance level (e.g., Helmholtz-Kohlrausch effect) or adaptation under extraordinary illuminant are not considered here.

2. DEVICE CHARACTERIZATION

For device independent color reproduction, every device must first be characterized. Calibration methods for the CRT monitor and the printer are briefly described in this section.

§ 2.1 Monitor Calibration

Monitors used in this experiment are Sony "GDM-2036" and Apple "Macintosh 16" Monitor". Both monitors are used as computer graphic monitors. These two monitors were calibrated by the model proposed by Berns et. al.^{7,8} The model consists of mainly two stages, i.e. the gamma correction for the CRT tube characteristic and the additive color mixture of red, green and blue channels. Device dependent RGB signals are transformed into XYZ tristimulus values by the equations below. Parameters in the first equation were derived from the ramp data of primary colors (red, green, and blue), and the matrix in the second equation was obtained by the regression technique.

$$\begin{aligned}
 r &= \frac{R}{R_{\max}} = k_{r,gain} \frac{dr}{255} + k_{r,offset} & r \\
 g &= \frac{G}{G_{\max}} = k_{g,gain} \frac{dg}{255} + k_{g,offset} & g \\
 b &= \frac{B}{B_{\max}} = k_{b,gain} \frac{db}{255} + k_{b,offset} & b
 \end{aligned}
 \quad \text{--- (2.1)}$$

$$\begin{array}{r}
 X \\
 Y \\
 Z
 \end{array}
 =
 \begin{array}{r}
 X_{R,\max} \\
 Y_{R,\max} \\
 Z_{R,\max}
 \end{array}
 \begin{array}{r}
 X_{G,\max} \\
 Y_{G,\max} \\
 Z_{G,\max}
 \end{array}
 \begin{array}{r}
 X_{B,\max} \\
 Y_{B,\max} \\
 Z_{B,\max}
 \end{array}
 \begin{array}{r}
 r \\
 g \\
 b
 \end{array}
 \quad \text{--- (2.2)}$$

The performance of the monitor calibration was evaluated using the 24 color patches in Macbeth ColorChecker®. All the colors were inside the monitors' gamut.

TABLE 2.1 Performance of the Monitor Calibration

Monitor Model	Ave. Color Difference ± Std. Deviation
Sony GDM-2036	E*ab = 0.97 ± 0.41
Macintosh 16" Monitor	E*ab = 1.90 ± 1.28

§ 2.2 Printer Calibration

The continuous ink jet printer Iris SmartJet 4012 was used for output device. 51x51x51 XYZ-to-CMY look-up-table (LUT) was generated by the following method⁹:

- 1) Produce 9x9x9 color chart sampled in input color space (CMY).
- 2) Measure the tristimulus values (XYZ) of the color chart under illuminant F6.
- 3) Interpolate inside the 9x9x9 color space to by the Lagrangean interpolation to make the 85x85x85 CMY-to-XYZ table.
- 4) Generate 51x51x51 table in device independent color space (XYZ).
- 5) Search the cube which includes given XYZ and calculate the corresponding signal CMY by linear interpolation using eight apices of the cube.
- 6) If the given XYZ is outside the gamut, it is clipped to the most saturated color inside the gamut while keeping lightness and hue constant.

Performance was evaluated using the Macbeth ColorChecker®'s 24 color patches. Every color except white (No.19) was inside the printer's gamut.

TABLE 2.2 Performance of the Printer Calibration

Printer Model	Ave. Color Difference ± Std. Deviation
Iris SmartJet 4012	E*ab = 1.92 ± 0.96

3. APPEARANCE MODELING

There are essentially three stages in this color appearance modeling: 1) transformation from tristimulus values to raw cone signals, 2) chromatic adaptation compensation, and 3) contrast matching. These stages are very similar to the signal processing used in 3 CCD color video cameras¹⁰. The CCD signals for red, green, and blue goes through 3x3 matrix circuit to fit RGB signals of the NTSC specification. These signals are then divided by the reference white's values to get a white-balanced image. Finally, these white-balanced signals are gamma-corrected for CRT tube's characteristics.

$$\begin{array}{cccccc}
X & & L & & L/L_n & (L/L_n) \\
Y & \tilde{M} & M & \text{White Balance} & M/M_n & \text{Contrast } (M/M_n) \\
Z & & S & & S/S_n & (S/S_n)
\end{array}$$

§ 3.1. Transformation from Tristimulus Values to Raw Cone Signals

First, tristimulus values are transformed to raw cone signals. L, M, S represents the cone signal for long wavelengths, middle wavelengths, and short wavelengths. The Hunt-Pointer-Estévez transformation matrix normalized to equi-energy illuminant is used, since it is desirable to normalize the cone signals for equality for the self-luminous colors⁵.

$$\begin{array}{cccccc}
L & 0.38971 & 0.68898 & -0.07868 & X & \\
M = & -0.22981 & 1.18340 & 0.04641 & Y & \text{--- (3.1)} \\
S & 0.0 & 0.0 & 1.0 & Z & E
\end{array}$$

§ 3.2. Chromatic Adaptation Compensation

Second, compensation is made for the change in color appearance according to the surroundings. The human visual system changes cone sensitivity of each channel to get an image white-balanced as in color video cameras. Basically, simple von Kries' adaptation model is used here, in which the signals of each channel are divided by the reference white's signals. However, the reference white point to which human visual system adapts must be investigated further.

There are two steps for the calculation of the reference white point. The first step is compensation for the incomplete chromatic adaptation^{2,3,4} of the human visual system for the self-luminous displays. The second step is compensation for the partial adaptation to the CRT monitor under ambient lighting.

3.2.1 Incomplete adaptation

Even if the monitors are placed in a totally dark room, human visual system will not completely adapt to a CRT monitor's white point which is significantly different from D65 illuminant^{2,3,4}. Adaptation becomes less complete as the chromaticity of the adapting stimulus deviates from the D65 and as the luminance of the adapting stimulus decreases. Incompletely adapted white point: $L'_{n(CRT)}, M'_{n(CRT)}, S'_{n(CRT)}$ can be expressed as CRT monitor's white point: $L_{n(CRT)}, M_{n(CRT)}, S_{n(CRT)}$ divided by the chromatic adaptation factors: p_L, p_M, p_S used by Hunt⁵ in his model.

$$L_{n(CRT)} = L_{n(CRT)}/p_L, \quad M_{n(CRT)} = M_{n(CRT)}/p_M, \quad S_{n(CRT)} = S_{n(CRT)}/p_S \quad \text{--- (3.2)}$$

$$p_L = \frac{(1 + Y_n^{1\beta} + l_E)}{(1 + Y_n^{1\beta} + 1/l_E)}, \quad p_M = \frac{(1 + Y_n^{1\beta} + m_E)}{(1 + Y_n^{1\beta} + 1/m_E)}, \quad p_S = \frac{(1 + Y_n^{1\beta} + s_E)}{(1 + Y_n^{1\beta} + 1/s_E)} \quad \text{--- (3.3)}$$

where,

$$\begin{aligned}
 l_E &= 3 L_{n(CRT)} / (L_{n(CRT)} + M_{n(CRT)} + S_{n(CRT)}) \\
 m_E &= 3 M_{n(CRT)} / (L_{n(CRT)} + M_{n(CRT)} + S_{n(CRT)}) \\
 s_E &= 3 S_{n(CRT)} / (L_{n(CRT)} + M_{n(CRT)} + S_{n(CRT)})
 \end{aligned}
 \quad \text{--- (3.4)}$$

where Y_n is the absolute luminance of the adapting stimulus in cd/m^2 and a subscript $n(CRT)$ refers to the CRT monitor's white point.

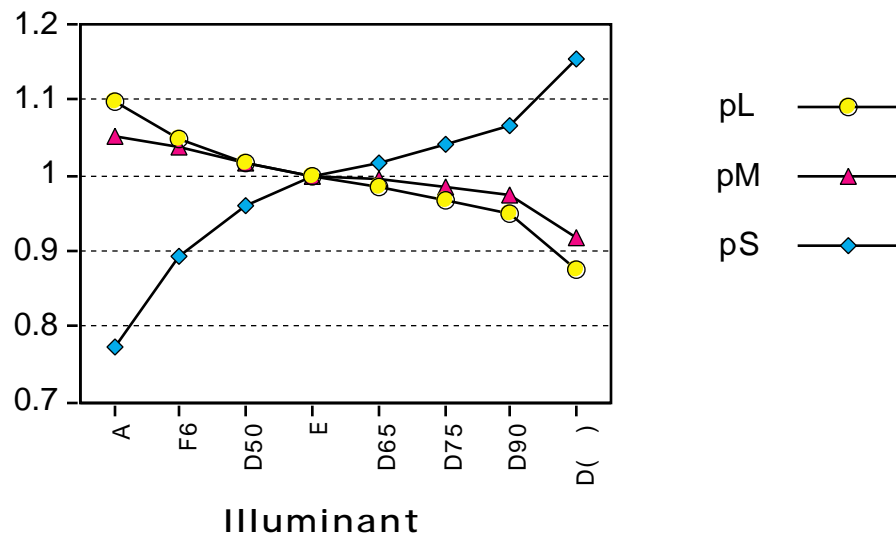

Fig. 3.1 Chromatic Adaptation Factors of Typical Illuminant at $Y_n = 100 \text{ cd/m}^2$

As shown in Fig. 3.1, the chromatic adaptation factors deviate from unity as they go away from equi-energy illuminant. For monitors used in this experiment, the following chromatic adaptation factors were used:

TABLE 3.1 Chromatic Adaptation Factors for Monitors Used for the Experiment

Monitor Model	CCT	(pL, pM, pS)
Sony "GDM-2036"	9000	(0.9493, 0.9740, 1.0678)
Macintosh 16" Monitor	6500	(0.9849, 0.9920, 1.0222)

3.2.2 Partial adaptation

In a typical office setting, soft copy images are rarely seen under dark conditions. The room is normally illuminated with fluorescent lighting having a CCT around 4150K. The CCT of the widely-used graphic monitor's white point is much higher than this lighting, usually around 9300K. In cases where both white points are different, it was hypothesized that the human visual system is partially adapted to the monitor's white point and partially to the ambient light's white point. Therefore, the adapting stimulus for human visual system for soft copy images can be expressed as an intermediate point of the two. Note the incompletely-adapted white point described above is used as the monitor's white point.

$$\begin{aligned}
L_{n(\text{SoftCopy})} &= R_{adp} L_{n(\text{CRT})} + (1 - R_{adp}) L_{n(\text{Ambient})} \\
M_{n(\text{SoftCopy})} &= R_{adp} M_{n(\text{CRT})} + (1 - R_{adp}) M_{n(\text{Ambient})} \\
S_{n(\text{SoftCopy})} &= R_{adp} S_{n(\text{CRT})} + (1 - R_{adp}) S_{n(\text{Ambient})}
\end{aligned}
\quad \text{--- (3.5)}$$

where R_{adp} is the adaptation ratio (0.0 - 1.0) to the CRT monitor. When R_{adp} equals 0.0, the human visual system is completely adapted to the ambient light and none to the monitor. This is conceptually close to the CIE/XYZ matching and output image will look much bluish in case that CCT of the monitor is higher than that of the ambient light. When R_{adp} equals 1.0, this means that eyes are totally adapted to the monitor's white point. Therefore, it is conceptually close to CIE/L*a*b* matching and output image will be much reddish or yellowish. The newly defined partially adapted white points are used for simple von Kries model hereafter.

§ 3.3. Contrast Matching

Another important effect of ambient lighting is the variation of the perceived image contrast in accordance with the surround's luminance level relative to the monitor's luminance. There are two main reasons. One is the human visual system's luminance-level adaptation and the other is the reflection of the ambient light on the CRT tube.

The former phenomenon was well-surveyed by the Bartleson and Breneman^{11,12}, and also employed in recent color appearance model RLAB⁴. A dark surrounding causes colors in the image appear lighter due to luminance-level adaptation¹³. Therefore, an excessive gamma of 1.5 is needed when viewing projected transparencies in "dark surround" to produce pleasing result. The soft copy images on CRT monitor are normally viewed in a "dim surround". In such a viewing condition, an excessive gamma of 1.25 is recommended^{14,15}.

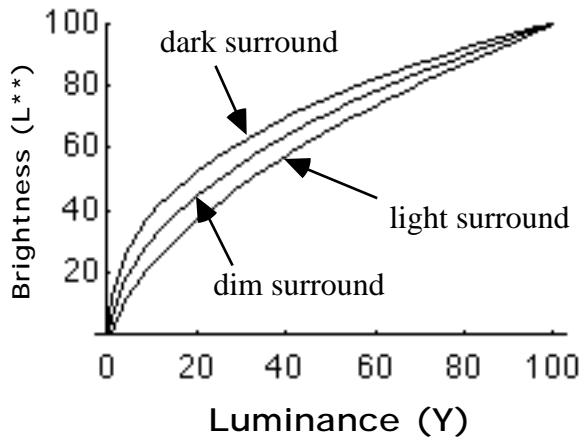

for a "light surround";

$$L^* = 11.5 \left\{ 100 \left(\frac{Y}{Y_n} \right) + 1.0 \right\}^{0.50} - 16$$

for a "dim surround";

$$L^* = 17.5 \left\{ 100 \left(\frac{Y}{Y_n} \right) + 0.6 \right\}^{0.41} - 16$$

for a "dark surround";

$$L^* = 25.4 \left\{ 100 \left(\frac{Y}{Y_n} \right) + 0.1 \right\}^{0.33} - 16$$

Fig. 3.2 Relationship between Brightness (L^{**}) and the Relative Luminance (Y)¹⁴

The latter phenomenon implies that the black on the CRT monitor will not be dark enough because the reflection of the ambient lighting still exists although most of the monitors have anti-glare filter on the surface of the CRT tube. Monitors have no means of producing black darker than this reflection, whereas black ink on hard copy print is much darker than this monitor's black.

For example, in the room used for this study, monitors showed following amount of fluorescent (F6) lighting's reflection. These values were measured by the Topcon "SR-1" spectro-radiometer

TABLE 3.2 Reflection on the CRT Tube in the Room Used for the Experiment

Monitor Model	X	Y (L*)	Z
Sony "GDM-2036"	5.51	5.80(L* = 29.99)	3.25
Macintosh 16" Monitor	4.13	4.43(L* = 21.79)	2.49

Since the human visual system is more sensitive to dark areas and less sensitive to light areas as the CIE L*a*b* equations imply, the contrast of the soft copy image will be weaker if the black is not dark enough. Therefore, an excessive gamma should be added to make the contrast of the two images appear the same.

Although this reflection of ambient light is not negligible, they are not considered in this experiment and left for a further study. As in RLAB, the gamma of 1.25 is used for the "dim surround", in which the soft copy images are normally viewed. The excessive gamma was added to cone response normalized by the partially adapted white point, whereas in RLAB they are added to normalized tristimulus values. Hereafter, these L*, M*, S* are abbreviated as SCR/L*M*S* representing indices for Soft copy Color Reproduction.

$$\begin{aligned}
 L/L_{n(SoftCopy)} &= \left\{ L/L_{n(HardCopy)} \right\}^{1.25} \\
 M/M_{n(SoftCopy)} &= \left\{ M/M_{n(HardCopy)} \right\}^{1.25} \\
 S/S_{n(SoftCopy)} &= \left\{ S/S_{n(HardCopy)} \right\}^{1.25}
 \end{aligned}
 \quad \text{--- (3.6)}$$

or in the inverse form,

$$\begin{aligned}
 L^* &= \left\{ L/L_{n(SoftCopy)} \right\}^{0.80} = L/L_{n(HardCopy)} \\
 M^* &= \left\{ M/M_{n(SoftCopy)} \right\}^{0.80} = M/M_{n(HardCopy)} \\
 S^* &= \left\{ S/S_{n(SoftCopy)} \right\}^{0.80} = S/S_{n(HardCopy)}
 \end{aligned}
 \quad \text{--- (3.7)}$$

§ 3.4. Transformation to CIE 1976 L*a*b*

If necessary, the following step can be added for image manipulation and/or gamut compression:

$$\begin{array}{rcccl}
 X^* & & 1.91020 & -1.11212 & 0.21990 & L^* \\
 Y^* & = 100 & 0.37095 & 0.62905 & 0.0 & M^* \\
 Z^* & & 0.0 & 0.0 & 1.0 & S^*
 \end{array}
 \quad \text{--- (3.8)}$$

SCR/L*M*S* are transformed to tristimulus values normalized to equi-energy illuminant. The matrix used here is the inverse of the Hunt-Pointer-Estévez transformation matrix used in equation (3.1). These X*Y*Z* are abbreviated as SCR/X*Y*Z*. Once converted into tristimulus values, they can be transformed to widely-accepted CIE 1976 L*a*b*, using normal L*a*b* equation¹⁷. Since the tristimulus values are normalized to equi-energy illuminant, reference white's values are (Xn, Yn, Zn) = (100, 100, 100).

$$\begin{aligned}
L^* &= 116 \left(Y^*/100 \right)^{1/3} - 16 & Y^*/100 & 0.008856 \\
a^* &= 500 \left[\left(X^*/100 \right)^{1/3} - \left(Y^*/100 \right)^{1/3} \right] & X^*/100 & 0.008856 \\
& & Y^*/100 & 0.008856 \\
b^* &= 200 \left[\left(Y^*/100 \right)^{1/3} - \left(Z^*/100 \right)^{1/3} \right] & Y^*/100 & 0.008856 \\
& & Z^*/100 & 0.008856
\end{aligned}
\quad \text{--- (3.9)}$$

Although these L^* , a^* , b^* are compatible with CIE 1976 $L^*a^*b^*$, they can be abbreviated as $SCR/L^*a^*b^*$ to distinguish from CIE $L^*a^*b^*$ if necessary. After the image manipulation and/or gamut compression, they are converted back to $SCR/L^*M^*S^*$ using the inverse of equation (3.9) and (3.8).

4. IMAGE TRANSFORMATION

Soft copy image data is transformed to hard copy image data as follows:

- 1) Device dependent signals (RGB) are transformed into device-independent color space (XYZ) through the monitor's profile.
- 2) Tristimulus values (XYZ) are transformed to actual cone signals ($SCR/L^*M^*S^*$) with viewing condition parameters through the above appearance model.
- 3) If necessary, $SCR/L^*M^*S^*$ are transformed to $SCR/L^*a^*b^*$ for image manipulation and/or gamut compression. After the image manipulation, they are converted back to $SCR/L^*M^*S^*$.
- 4) The actual cone signals ($SCR/L^*M^*S^*$) are then converted to tristimulus values (XYZ) under the illuminant where hard copy image will be viewed through the simple von Kries adaptation model.
- 5) The tristimulus values (XYZ) are converted to device-dependent signals (CMY) for the ink jet printer through the printer's profile.

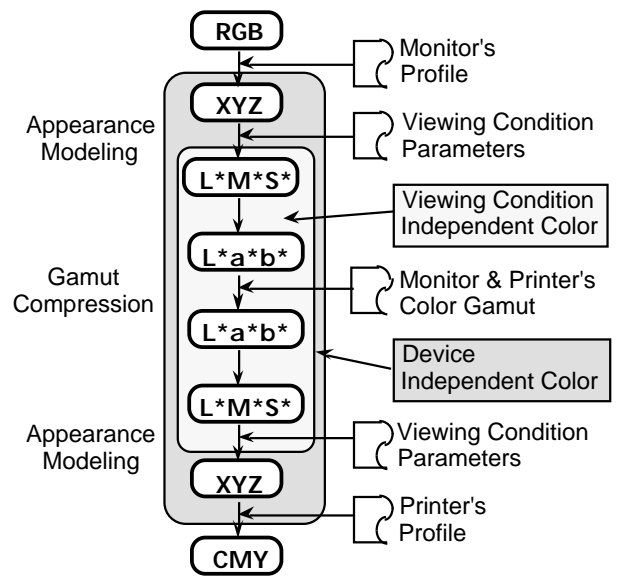

Fig. 4.1 Flow Chart of the Image Transformation

5. VISUAL EXPERIMENT

A visual experiment was performed to find the best adaptation ratio R_{adp} for the soft copy images. The image used was the portrait of young lady wearing a yellow shirt, a red cap and holding blue and green objects, with grayish background. Histograms of the image pixels in $SCR/L^*a^*b^*$ are shown in Fig. 5.1, 5.2, 5.3, respectively. The image (1024 x 1536 pixels: RGB 8bits) was displayed on the CRT screen at 72 dpi at a half of its size (177mm x 267mm) with 100% white patches as a reference in the uniform gray background. The settings of CRT monitors used in this experiment are as follows.

TABLE 5.1 Monitor Settings for the Visual Experiment

Monitor Model	Luminance	CCT
Sony "GDM-2036"	120.99 cd/m ²	9000
Macintosh 16" Monitor	87.44 cd/m ²	6500

The room had a fluorescent (F6: 4150K) lighting at an illuminance of about 500-600 lux. A white paper set next to the monitor had a luminance around 100 cd/m². Transformed hard copy images through the procedure above were reproduced by the Iris SmartJet printer at the resolution of 150 dpi (171mm x 256mm).

Images at six levels of the soft copy adaptation ratio R_{adp} (0, 20, 40, 60, 80, 100%) were reproduced and used for the paired comparison experiment. Fifteen pairs were formed from those six images. Before the experiment, observers were given a few minutes to adapt to the viewing conditions of the room. Observers were instructed to sit approximately 50-60 cm from the screen and to identify better matching image to the soft copy image on the monitor from a given pair of hard copy images. Observers could move the pair of the images anywhere he/she desired, but not on the screen next to soft copy image. No time restriction was placed on the observers. Fifteen color-normal observers (12 male and 3 female; ages from 23 to 38; average 29.6) participated. Using Thurstone's law of comparative judgement, ordinal-scale visual decisions were converted to the interval psychometric scale.

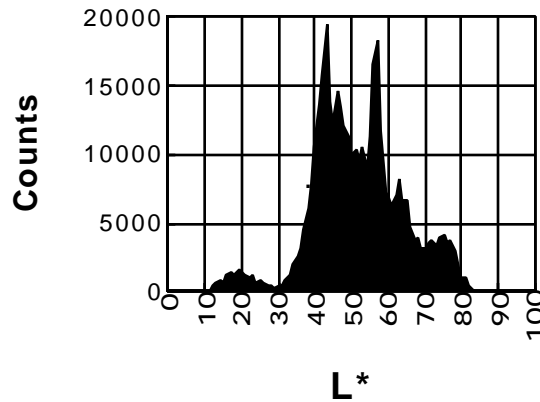

Fig. 5.1 Histogram of the Image Pixels (L^)*

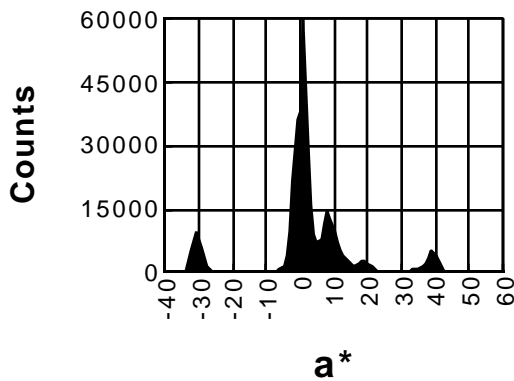

Fig. 5.2 Histogram of the Image (a^)*

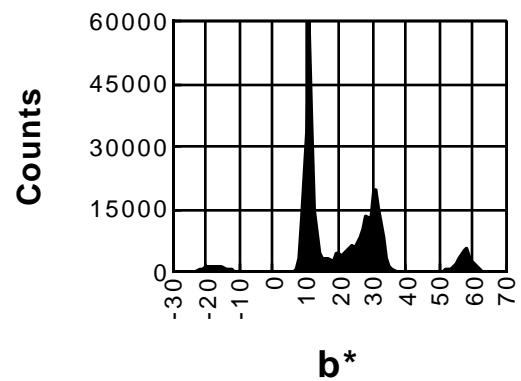

Fig. 5.3 Histogram of the Image (b^)*

6. RESULTS

As shown in Figures 6.1 and 6.2 below, the most preferred image was 60% adapted to the CRT monitor for both monitors. The 40% CRT-adapted image was the next preferred one. The 20% CRT-adapted image was chosen third. The 100% CRT-adapted and the 100% ambient-light-adapted image had two of the lowest scores, meaning that neither CIE/XYZ matching or CIE/L*a*b* matching image are acceptable for soft copy color reproduction.

Even though two monitors used in this experiment had a white point of different CCT, almost the same trend was found on both results of the visual experiment. This implies that adaptation ratio is independent of the CCT of the monitor's white point.

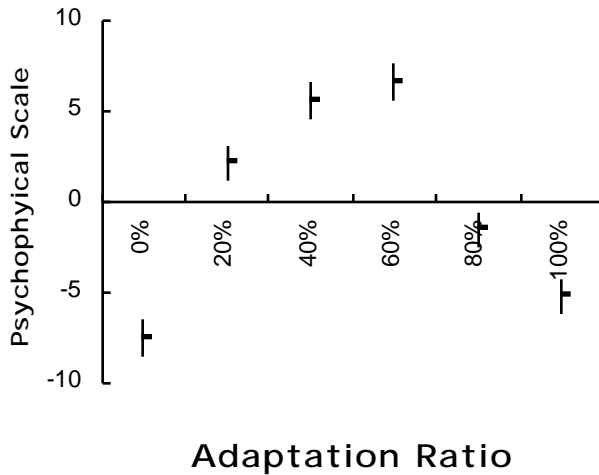

Fig. 6.2 Sony GDM-2036 (9000K)

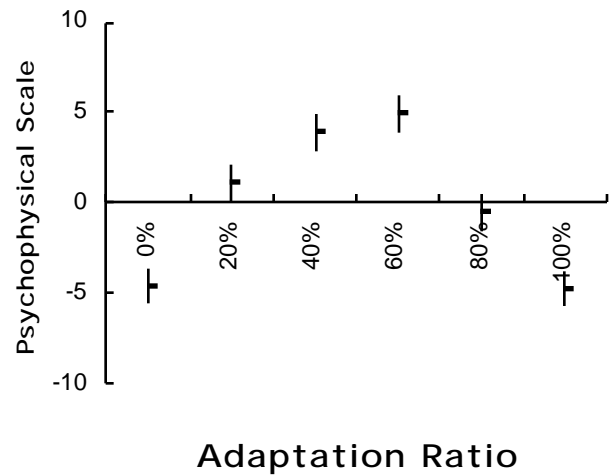

Fig. 6.1 Macintosh 16" Monitor (6500K)

At the end of the visual experiment, observers also asked if he/she could find any hard copy image that closely matches the soft copy image on the monitor. Although these answers were not statistically treated, most observers answered that 60% and/or 40% CRT-adapted image was an acceptable reproduction of the original. However, some mentioned that those images are not still sufficient and need to be improved.

7. DISCUSSION

The visual experiment generated some problems for further study.

Although the adaptation ratio R_{adp} was independent of the chromaticity of the monitor's white point, it was dependent on other parameters, e.g., viewing time of the soft copy image t_{st} and the viewing angle of the CRT screen θ_{view} . It can also be assumed that the adaptation ratio is a function of the absolute luminance of white on the screen $Y_{n,CRT}$ and white on paper $Y_{n,Ambient}$. They were not considered in this experiment since the luminance of the two were comparatively the same. The adaptation ratio can be expressed as a function of above parameters.

$$R_{adp} = f\left(t_{st}, \theta_{view}, Y_{n,CRT}, Y_{n,Ambient}\right) \quad \text{--- (7.1)}$$

The chromatic adaptation mechanism is quite rapid, while the luminance-level adaptation takes several minutes². It only takes 10 to 20 seconds to reach the steady state of adaption. Since no restrictions were placed on the observers for the viewing time of the images, some observers required significant time while others made quick decisions. This implies that prudent observers preferred the 60% monitor-adapted image while quick observers preferred the 40% monitor-adapted image. However, since the images at other adaptation ratio were not preferred, it is assumed that best adaptation ratio can be found between 60% and 40%.

The viewing angle of the screen also has a big effect on the adaptation ratio. When closer to the screen or larger the screen size, the eyes are adapted more to monitor's white point. Fairchild also has performed the experiment on the relationship between an adaptation ratio and a background field width². The adaptation ratio is asymptoting at 58%, as in his previous experiment. A mere viewing angle of 4 degree is necessary to be close to the steady state, although the adaptation ratio decreases dramatically below the 4 degree.

Second, as mentioned in §3.3, reflection of the ambient light on the CRT tube is not negligible, although it was not considered in this study. The excessive gamma $\gamma_{cont.}$ should be expressed as a function of not only the luminance of white of monitor and ambient light, but also function of black of monitor $Y_{b,CRT}$ and hard copy's black $Y_{b,Ambient}$.

$$\gamma_{cont.} = f(Y_{n,CRT}, Y_{n,Ambient}, Y_{b,CRT}, Y_{b,Ambient}) \quad \text{--- (7.2)}$$

Lastly, the reflection of the ambient light not only makes black lighter but also makes every color shift toward white, meaning all the colors become less saturated. All the colors produced by the phosphor are mixed with the screen reflection. Therefore, tristimulus values of the soft copy can be expressed as a sum of the phosphor's light and the reflection of the screen. This phenomenon must also be investigated further.

$$\begin{aligned} X'_{CRT} &= X_{CRT} + X_{b,Ambient} \\ Y'_{CRT} &= Y_{CRT} + Y_{b,Ambient} \\ Z'_{CRT} &= Z_{CRT} + Z_{b,Ambient} \end{aligned} \quad \text{--- (7.3)}$$

8. CONCLUSION

It was found that human visual system is 60% (to 40%) adapted to CRT monitor's white point and 40% (to 60%) to the ambient light when seeing a soft copy image on the CRT monitor under ambient lighting. This adaptation ratio itself was found to be independent of the chromaticity of the monitor's white point. The reproduced hard copy image at 60% and 40% adaptation ratio had acceptable matching to the original soft copy image on CRT. These appearance-matched image had much better reproduction than CIE/XYZ-matched or CIE/L*a*b*-matched images. Thus, this method can be used to improve soft copy color reproduction to match the hard copy color.

Furthermore, since this model is compatible with CIE 1976 L*a*b*, hard copy images in CIE/L*a*b* format can be transferred to the monitor and transformed into the image that matches the original under initial viewing conditions. Conversely, soft copy images on the monitor can also be transferred to an output device.

9. ACKNOWLEDGMENT

The author would like thank all the observers who participated in the visual experiment. Special thanks are given to Mr. A. Oryo for his assistance in making the printer's profile and to Ms. J. Ikegami for modeling for the images used in the experiment.

10. REFERENCES

1. H. Ikegami, "Activity of Color Facsimile Standardization --- Selection of Color Space ---", *Proc. of the 9th Joint Conf. on Color Technology*, 39-44, Tokyo, (1992)
2. M. D. Fairchild, "Chromatic Adaptation to Image Displays", *TAGA Proc.*, Vol. 2, 803-823, Rochester, (1992)
3. M. D. Fairchild, "Formulation and Testing of an Incomplete-Chromatic-Adaptation Model", *Color Res. Appl.*, Vol 16, 243-250, (1991)
4. M. D. Fairchild, R. S. Berns, "Image Color-Appearance Specification Through Extension of CIELAB", *Color Res. Appl.*, Vol 18, 178-190, (1993)
5. R. W. G. Hunt, "Revised Colour-Appearance Model for Related and Unrelated Colours", *Color Res. Appl.*, Vol 16, 146-165, (1991)
6. Y. Nayatani, K. Takahama, H. Sobagaki, K. Hashimoto, "Color Appearance Model and Chromatic-Adaptation Transform", *Color Res. Appl.*, Vol 15, 210-221, (1990)
7. R. S. Berns, R. J. Motta, M. E. Gorzynski, "CRT Colorimetry. Part I: Theory and Practice", *Color Res. Appl.*, Vol 18, 299-314, (1993)
8. R. S. Berns, R. J. Motta, M. E. Gorzynski, "CRT Colorimetry. Part II: Metrology", *Color Res. Appl.*, Vol 18, 315-325, (1993)
9. P. C. Hung, "Colorimetric Calibration in Electronic Imaging Devices Using Look-up-Table model and Interpolations", *J. Electronic Imaging.*, Vol 2, 53-61, (1993)
10. N. Katoh, "Colorimetric Optimization of a NTSC Color Video Camera", *Munsell Color Science Lab. Technical Report*, Aug, (1992)
11. C. J. Bartleson, "Optimum Image Tone Reproduction", *J. SMPTE*, Vol 84, 613-618, (1975)
12. C. J. Bartleson, E. J. Breneman, "Brightness Perception in Complex Fields", *J. Opt. Soc. Am.*, Vol 57, 953-957, (1967)
13. I. T. Pitt, L. M. Winter, "Effect of Surround on Perceived Saturation", *J. Opt. Soc. Am.*, Vol 64, 1328-1331, (1974)
14. W. N. Sproson, *Color Science in Television and Display System*, Adam Hilger Ltd. (1983)
15. R. W. G. Hunt, *The Reproduction of Colour in Photography, Printing & Television*, Fountain Press (1987)
16. B. Saunders, "Visual Matching of Soft Copy and Hard Copy", *J. Imaging Tech.*, Vol 12, 35-38, (1986)
17. *Colorimetry*, 2nd ed., CIE Publication No.15.2, Central Bureau of the CIE, Vienna, (1986)